

# The Chronological Assessment of Suicide Events: A Practical Interviewing Strategy for the Elicitation of Suicidal Ideation

Shawn Christopher Shea, M.D.

© Suicide assessment is one of the cornerstones of daily clinical practice for both mental health professionals and primary care clinicians. A practical interviewing strategy for efficiently eliciting valid suicidal ideation is presented. The strategy is illustrated via a reconstructed interview designed to highlight key teaching points. The strategy, the Chronological Assessment of Suicide Events (CASE Approach), helps the clinician to uncover critical data in four contiguous time frames: (1) presenting suicidal ideation/behavior, (2) recent suicidal ideation/behaviors, (3) past suicidal ideation/behaviors, and (4) immediate suicidal ideation. The CASE Approach is an easily learned interviewing strategy, designed for busy, frontline clinicians in both the mental health and primary care settings.

*(J Clin Psychiatry 1998;59[suppl 20]:58-72)*

In the United States a suicide is completed approximately every 20 minutes—over 25,000 per year.<sup>1</sup> Suicide ranks as the ninth leading cause of death in adults, and, after accidents and homicides, it ranks as the most common cause of death in 15- to 24-year-olds.<sup>2</sup> Suicide assessment is a daily task for mental health professionals and primary care clinicians. Studies have indicated that in roughly 40% to 60% of the cases in which patients completed suicide, they had been seen by a physician (usually not a psychiatrist) in the preceding month.<sup>3,4</sup>

Suicide assessment consists of essentially three parts: (1) the elicitation of suicidal ideation from the patient (corroborative sources are also critical); (2) the gathering of data concerning the known factors increasing suicidal risk, such as age, sex, use of alcohol or presence of psychosis; and (3) the clinical decision making itself, in which the clinician weighs the acute danger as indicated by the patient's suicidal ideation and the presence of risk factors.

A valuable and comprehensive literature exists devoted to the latter two parts of suicide assessment, delineating the role of risk factors and the art of clinical decision making. This literature consists of empirical research and practical clinical wisdom. In contrast, substantially less has been written concerning specific interviewing techniques

and strategies for eliciting suicidal ideation itself, other than to remind the reader that such questioning should be conducted. But there is little doubt that two clinicians, after assessing suicidal ideation in the same patient, can walk away with a surprisingly different database, depending upon how the questions were phrased and the degree to which the patient liked and trusted the interviewer.

The practical problems related to uncovering a sound history of suicidal ideation are compounded for both the mental health professional and the primary care professional practicing in today's climate. Time constraints related to managed care pressures, limited staffing with increased work loads, and an increasingly litigious society put pressures on clinicians, who are already quite pressured.

Moreover, difficult suicide assessments have a knack for occurring at complicated times. They often happen in the middle of an extremely hectic clinic day or in the chaotic environment of a packed emergency room. And the stakes are high. An error can result not only in an unnecessary death—a terrible tragedy—but also in a lawsuit, much less important but very disturbing in its own right. Thus, in many suicide assessment scenarios we find a harried clinician performing a difficult task, under extreme pressure, in an unforgiving environment. It is no wonder that mistakes are made.

One possible method of decreasing the number of these mistakes is to provide the frontline clinician with an easily learned and practical interviewing strategy, one that will be reliably utilized no matter how tired or overwhelmed the clinician may be or how hectic the clinical environment may have become.

The goal of this paper is to present such a strategy—the Chronological Assessment of Suicide Events (CASE Ap-

---

*From the Department of Psychiatry, Dartmouth-Hitchcock Medical Center, Dartmouth Medical School, Lebanon, N.H.*

*Presented at the symposium "Depression and Anxiety: New Tools for Diagnosis and Treatment," August 15, 1997, Chicago, Ill., which was supported by an unrestricted educational grant from SmithKline Beecham.*

*Reprint requests to: Shawn Christopher Shea, M.D., 1502 Route 123 North, Stoddard, NH 03464.*

proach). It has been refined over the course of 15 years of developing interview training programs for psychiatric residents and other mental health professionals at both the Western Psychiatric Institute and Clinic in Pittsburgh, Pennsylvania<sup>5,6</sup> and the Dartmouth Medical School in Lebanon, New Hampshire.

The CASE Approach was developed with the following objectives: (1) The approach should be easily learned; (2) The approach should be easily remembered; (3) The approach should not require any written prompts; (4) The approach should help to ensure that the numerous data regarding suicidal ideation are comprehensively covered (to decrease errors of omission); (5) The approach should help to increase the validity of the information elicited from the patient (whether a denial of suicidal ideation or an endorsement of the extent of ideation and planning); (6) The approach should be easily taught; and (7) The approach should be behaviorally concrete enough that it can subsequently lend itself to empirical study.

By the end of this paper, the clinician will have been introduced to a practical suicide elicitation strategy that can be immediately put to the test with modifications that meet the needs of the individual clinician and the patient population that the clinician serves. The CASE Approach is not presented as the “right way” to elicit suicidal ideation. It is merely one way that invites clinicians to ask themselves questions, such as, “How do I ask about suicidal ideation in my own practice?” “Are the practical aspects of this approach easily taught to other clinicians?” and “Should elements of the CASE Approach, different from my current approach, be incorporated into my interview strategy?”

The CASE Approach began with a study of interviewing techniques endorsed by experts as methods of increasing the validity of any elicited data. These specific validity techniques were then incorporated into a strategy for the elicitation of suicidal ideation itself. In this paper, the CASE Approach will be presented in two sections—a brief review of the specific validity techniques it was based on and a description of the CASE Approach itself.

### **VALIDITY TECHNIQUES UTILIZED IN THE CASE APPROACH**

It should be remembered that the following validity techniques were not developed with suicide assessment in mind. They were devised to increase the likelihood of receiving a valid response to any question that might raise sensitive issues for the patient. These techniques were created to help clinicians explore traditionally sensitive areas, such as sexual history, physical and sexual abuse histories, alcohol and drug abuse histories, and suicidal and homicidal ideation.

They are also of use exploring any topic a specific patient does not want to discuss, even for idiosyncratic reasons. For example, if a primary care patient taking theo-

phylline were asked about breathing problems at night, these problems might represent a sensitive area for that patient, an area in which validity would be suspect. The patient who disliked the side effects of theophylline might well underreport symptoms to avoid an increase in dosage. The following validity techniques are as useful with a patient minimizing medical symptoms as with a patient who might be sharing suicidal planning.

Even though the focus of this paper will be on using these validity techniques in suicide assessment, their definitions and descriptions will allow the clinician to generalize their use to any sensitive area. Descriptions of three validity techniques—the Behavioral Incident, Gentle Assumption, and Denial of the Specific—follow.

#### **Behavioral Incident**

A patient may provide distorted information for a number of reasons, including anxiety, embarrassment, a desire to protect family secrets, defense mechanisms such as rationalization and denial, and conscious attempts to deceive. These distortions are more likely to appear when the clinician asks a patient for opinions rather than behavioral descriptions of events or the patient's thoughts.

Behavioral Incidents, originally developed by Gerald Pascal,<sup>7</sup> are questions that ask for specific facts, details, or trains of thought, as with “Exactly how many pills did you take?” or that simply ask the patient to describe what happened next, as with “What did you do then?” By using a series of Behavioral Incidents, the clinician is asking the patient to recreate the episode step by step.

For instance, if the clinician asks whether a patient dates frequently, the response may be a simple “yes”; the patient may be embarrassed to relate an infrequent dating pattern. To avoid this possibility, the clinician might ask the patient to recount specific dates over the past several years and ultimately the past several months. This way, the clinician can discover a lack of dating activity without necessarily embarrassing the patient. As Pascal observes, it is generally best for clinicians to make their own judgments based on the details of the story itself rather than to rely on patients objectively to describe matters that have strong subjective implications. Some typical Behavioral Incidents follow:

Prototypes:

- What did your father say then?
- Did you put the razor blade up to your wrist?
- When you say you “threw a fit,” what exactly did you do?
- How many bottles of pills did you store up?
- Tell me what happened next.

**Clinical Caveat:** Behavioral Incidents are outstanding at uncovering hidden information, but they are very time-consuming. The time it would take to do a full initial as-

assessment using only Behavioral Incidents would be impractical. Obviously the clinician must choose when to utilize Behavioral Incidents, emphasizing sensitive areas such as lethality, abuse, and medication noncompliance.

### **Gentle Assumption**

Gentle Assumption, originally developed by Pomeroy, Flax, and Wheeler<sup>8</sup> for use in eliciting a valid sex history, is used when a clinician suspects that a patient may be hesitant to discuss a specific behavior. With Gentle Assumption, the clinician assumes that the potentially embarrassing or incriminating behavior is occurring and frames his or her question accordingly. In uncovering a valid sexual history, it was discovered that questions, such as "How frequently do you find yourself masturbating?" were much more likely to yield valid answers than "Do you masturbate?" If the clinician is concerned that the patient may be disconcerted by the assumption, it can be softened by adding "if at all," as with "How often do you find yourself masturbating, if at all?" If engagement has gone well, patients are seldom bothered by Gentle Assumption.

Prototypes:

- What other types of street drugs do you like to use?
- How many times a week do you and your wife argue?
- How many jobs have you been fired from?
- What other ways have you thought of killing yourself?

Clinical Caveat: Gentle Assumptions are powerful examples of leading questions. The clinician must use them with care. They should not be used with patients who are trying to please the clinician or with patients who are trying to guess what the clinician wants to hear. They are inappropriate with most children, when they could lead to the relating of false memories of abuse.

### **Denial of the Specific**

After a patient has denied a generic question, such as "What other street drugs have you used?" it is surprising how many positive responses will be uncovered if the patient is asked a series of specific questions. This technique, originally developed by Shea,<sup>9</sup> appears to jar the memory of the patient, and it also appears to be harder to falsely deny a specific as opposed to a generic question. Examples of Denial of the Specific concerning drug abuse would be: "Have you ever tried cocaine?" "Have you ever smoked crack?" "Have you ever used crystal meth?" and "Have you ever dropped acid?"

Prototypes:

- Have you thought of shooting yourself?
- Have you thought of overdosing?
- Have you thought of hanging yourself?

Clinical Caveat: It is important to frame each Denial of the Specific as a separate question, pausing between each inquiry and waiting for the patient's denial before asking the next question. The clinician should avoid combining the inquiries into a single question, as with "Have you thought of shooting yourself, overdosing, or hanging yourself?" A series of questions combined in this way is called a "cannon question." Clinicians are tempted to use cannon questions because they think they are screening many areas with a single question. Unfortunately, cannon questions frequently confuse patients, and they only hear parts of them or choose to respond to only one part. Consequently, the clinician can come to the mistaken conclusion that the patient has given negative answers in all cases.

## **OVERVIEW OF THE CASE INTERVIEWING STRATEGY**

In the preceding section, the validity techniques laying the foundation for the CASE Approach were described. The next step in the development of the strategy consisted of answering the two-part question, "Why do interviewers frequently miss important data while eliciting suicidal ideation, and is there a way to decrease such errors of omission?" The answers lay in the supervision tool known as "facilics."<sup>10</sup> Facilics is the study of how clinicians structure interviews and utilize time. In recent years, facilics has become a popular tool for training clinicians efficiently and sensitively to perform the DSM-IV diagnostic intake interview under the tight time constraints of busy clinics and managed care environments.

According to facilics, clinicians tend to make more errors of omission as the amount and range of required data increase. Errors of omission decrease if the clinician can split a large amount of data into smaller, well-defined regions. With such well-defined and limited data regions, the clinician can more easily recognize when a patient has wandered from the subject. The clinician is also more apt easily to recognize whether the desired inquiry has been completed and does not feel as overwhelmed by the interview process. If the required data within each region are logically developed, they make sense to the interviewer, requiring little memorization. Such a simplified interview format is easily learned and hard to forget, providing a reliable interview strategy available on a consistent basis no matter how stressed the clinician may feel.

In suicide assessment, the clinician organizes the sprawling set of clinically relevant questions into four smaller and more manageable regions, each representing four contiguous time frames from the distant past to the present. In each region the clinician investigates the suicidal ideation and actions present during that specific time frame. Generally, each region is explored thoroughly before moving to the next; the clinician consciously chooses not to move onward unless there is a very good

**Figure 1. CASE Approach: Chronological Assessment of Suicide Events**

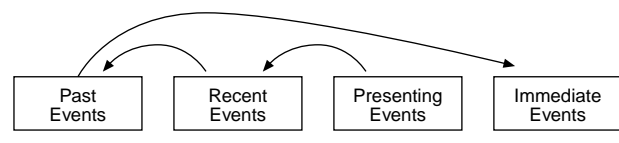

reason to do so. In the CASE Approach, the clinician explores the following four regions in this order: (1) the presenting ideation and suicidal behavior; (2) any recent ideation and behaviors (over the preceding 8 weeks); (3) past suicidal ideation and behaviors; and (4) immediate ideation and plans for the future (Figure 1). Note that the term “suicide event” includes both suicidal ideation and suicidal behavior.

This conversational pathway seems to flow smoothly for most patients. The clinician can and should alter the format, depending on the needs of any specific patient. For most patients, once the topic of suicide has been raised, it seems natural to talk about the presenting attempt first, if one exists. Next, it feels logical to discuss recent ideation and, subsequently, past ideation.

When performed sensitively by the interviewer, these explorations of the past generally improve both engagement and trust, as the patient realizes that it is okay to talk about suicidal ideation. Once trust has been maximized, it is an opportune time to explore current suicidal plans and intentions, the single most important area of a suicide assessment. Here the most subtle nuances of facial expression or hesitancy of speech may indicate that a suicide attempt is imminent.

One of the apparent appeals of the CASE Approach is that it is very simple. It is easy to remember and, indeed, hard to forget. Most clinicians relate that, once they have studied it, the technique naturally comes to mind as soon as they begin an exploration of suicidal ideation.

All that remains is to examine information important to explore in each time frame, always attempting to simplify the task by organizing the material into logical subcomponents and strategies. First, though, a few points are worth emphasizing.

It is important to remember that the CASE Approach is a flexible interview strategy devoted solely to the elicitation of suicidal events. It is not a complete interview and is always employed within the body of some other clinical interview, such as an initial assessment or emergency room assessment. Neither is the CASE Approach a method of collecting the risk factors for suicide; such information will be gathered in other areas of the overall interview. For example, the role of ongoing alcohol use will be explored in the history of substance abuse, the presence of psychosis will be explored in the examination for psychotic disorders, the availability of support systems will be assessed in the social history. Instead, the CASE Approach focuses

solely on gathering information about the presence and extent of suicidal ideation and intent itself. The CASE Approach complements the very important interview dedicated to uncovering suicide risk factors.

It is also important to remember that the CASE Approach is a method not for making a clinical decision but for gathering information from which an effective clinical decision can be made. Data gathering is part of the first step in a suicide assessment. The final step, assessing that data, is not the domain of this paper.

### Step 1: Exploration of Presenting Suicidal Events

If a patient presents with a suicide attempt or gesture or with pressing suicidal ideation, it becomes critical to understand the severity of the event. Depending on the severity of the ideation or attempt, the patient may require hospitalization or further crisis intervention. Primary care clinicians must decide whether a mental health referral is needed, perhaps even immediate crisis assessment and/or hospitalization. But what specific information would give the clinician the most accurate picture of the seriousness of a presenting suicide gesture or attempt? The answer lies in entering the patient’s world at the time of the suicide attempt, to find out exactly how close the patient came to completing suicide. How does the patient feel about the fact that he or she did not die?

1. How did the patient try to commit suicide? (What method was used?)
2. How serious was the action taken with this method? (If the patient overdosed, what pills and how many were taken? If the patient cut himself, where was the cut, and did it require stitches?)
3. How serious were the patient’s intentions? (Did the patient tell anyone about the attempt afterwards? Did the patient hint to anyone beforehand? Did the patient make the attempt in an isolated area or in a place where he or she was likely to be found? Did the patient write a will, check on insurance, write suicide notes, or say good-bye to significant others in the days preceding the event?)
4. How does the patient feel about the fact that the attempt was not completed? (A very good question here is “What are some of your thoughts about the fact that you are still alive now?”)
5. Was the attempt well planned or an impulsive act?
6. Did alcohol or drugs play a role in the attempt?
7. Were interpersonal factors a major role in the attempt? These factors might include feelings of failure or speculation that the world would be better off without the patient, as well as anger toward others (a suicide attempt undertaken to make others feel guilt).
8. Did a specific stressor or set of stressors prompt the attempt?

9. At the time of the attempt, how hopeless did the patient feel?
10. Why did the attempt fail? (How was the patient found, and how did the patient finally get help?)

Answers to such questions can provide the best information available regarding how serious the patient's attempt was. Statistical risk factors will not reveal whether a given patient intended death or not. Aside from patients who may accidentally kill themselves during staged, manipulative gestures, people kill themselves because they have decided to kill themselves. Suicide is not only an act of the heart but a cognitive decision.

For this reason it is important to answer the questions described above, but at first glance, especially for a clinician in training, this list of questions may appear intimidating to remember. The validity technique discussed earlier, the Behavioral Incident, can provide the clinician with a simpler and more logical approach than memorization. Behavioral incidents are utilized when the clinician asks for a specific piece of data (e.g., "Did you put the gun up to your head?") or asks the patient to continue a description of what happened sequentially (e.g., "Tell me what you did next."). In the CASE Approach, during the exploration of the Presenting Event, the interviewer asks the patient to describe the suicide incident itself, from beginning to end. During this description the clinician gently, but persistently, utilizes a series of Behavioral Incidents, guiding the patient to create a "verbal videotape" step by step. If a piece of the account is missing, the clinician returns to that area, exploring with a series of clarifying Behavioral Incidents, until the clinician feels confident that he or she has an accurate picture of what happened. Using such an approach, the clinician will frequently cover all of the material described above in a naturally unfolding dialogue, without much need for memorization.

Let's see this strategy at work with a 67-year-old retired history teacher and football coach from a local high school, whom I will call Mr. Rafferty. The night before this interview, he had been seen in the emergency room by a crisis worker, following an overdose. He had been brought in by his best friend, who seemed both reliable and concerned, commenting, "I've been worried about Jimmy for a while now." Mr. Rafferty refused hospitalization but agreed to be seen the next day by a therapist for possible admission to a crisis group.

Much of Mr. Rafferty's pain stems from the recent downswing in his wife's health. She has been valiantly coping with severe rheumatoid arthritis and diabetes for years. Unfortunately, the devastation wrought by the diseases is such that she will probably need to be transferred to a nursing home soon, and Mr. Rafferty is understandably torn apart by the situation.

Mr. Rafferty has weathered many battles successfully over the years but sees no end to the current war. With the

passing of time, gravity has added a chin or two to his large-jawed face. He is generally big-boned and moves with a slow but steady sense of purpose. A parade of cigarette packs has added a patchwork of thick wrinkles to his forehead and cheeks. He still sports a full head of hair whose uniformly brown color suggests the use of a drug store bottle. He greets the clinician with a fairly firm handshake and a weary smile. Let's pick up the conversation well into the body of the initial interview, when the clinician has decided carefully to explore suicide potential using the CASE Approach, entering the region of the Presenting Event.

**Clinician:** It was my understanding from the crisis worker, Mary, that...

**Patient:** You know, I taught Mary in high school, believe it or not.

**Clinician:** Oh. Was it uncomfortable for you to talk with her last night?

**Patient:** I think it was more uncomfortable for her. She did a great job. It went fine (pause). I must have taught her well. (Manages a faint smile.)

**Clinician:** She really is an outstanding clinician. I'll let her know that you appreciated her help. In any case she said you had overdosed last night. Tell me a little bit about what happened.

**Patient:** Sort of stupid. I just felt like I couldn't take it any more. I've been feeling that off and on now for a while. So I took some pills; it was really stupid. I know suicide is not the answer.

**Clinician:** Help me to get a good picture of what was going on for you, Mr. Rafferty. Sort of walk me through what was happening yesterday. For instance, when did the thoughts of overdosing start for you yesterday? (**Behavioral Incident**)

**Patient:** I thought about it a little bit in the afternoon, but only in a passing sense. Nothing serious. I'd been feeling bad all day. After dinner, I forced myself to go to my Masons meeting (pause). Are you familiar with the Masons?

**Clinician:** Not a lot, but I know a little.

**Patient:** It's a good organization (Said with a weary blandness. Mr. Rafferty seems to be defending one of his most cherished interests almost out of habit.) You ought to consider joining it. You know, George Washington and Ben Franklin were members. It's not that weird stuff you hear about. Masons do a lot of good.

**Clinician:** I've heard very good things about Masonry; maybe we can talk about it more later. But first, why don't you fill me in a little bit more about last night. You had come back from your meeting. What happened next? (**Behavioral Incident**)

**Patient:** (Patient sighs.) When I came back, Jennifer was asleep already. I stayed downstairs in the

living room, trying to watch TV, but I just couldn't. It seemed so depressing down there. And suddenly I just felt like I couldn't take it any more and I started to cry. . . I don't usually cry.

- Clinician:** Sounds like a very painful moment. (Mr. Rafferty nods his head.) What happened next? **(Behavioral Incident)**
- Patient:** I don't know what got into me. I walked out to the kitchen and got out some Tylenol tabs I keep for my back.
- Clinician:** Had you been thinking of killing yourself earlier in the day?
- Patient:** Like I said. Not really. Just a little.
- Clinician:** Had you done anything earlier in the day like writing a suicide note? **(Behavioral Incident)**
- Patient:** Heavens, no. I really hadn't thought about it a lot. That's why I am sort of surprised about what happened. I can't really explain it.
- Clinician:** Okay. Tell me what happened next. **(Behavioral Incident)**
- Patient:** I just decided I was gonna do it. So I just took 'em.
- Clinician:** Were you drinking at the time? **(Behavioral Incident)**
- Patient:** Oh no, I don't drink. I haven't had a drink in years.
- Clinician:** How many pills did you actually take, Mr. Rafferty? **(Behavioral Incident)**
- Patient:** Oh, not many.
- Clinician:** What's your best guess? **(Behavioral Incident)**
- Patient:** Five, maybe six or seven tops.
- Clinician:** What do you think stopped you from taking more?
- Patient:** I really don't know for certain (pause). One thing was, one thing was that I thought about how much Jennifer has suffered, and I said to myself, "If she can tough it out, my God, I ought to be able to." (Mr. Rafferty pauses; his eyes well up with tears.)
- Clinician:** You look sad right now. What are you feeling? **(Behavioral Incident)**
- Patient:** (Mr. Rafferty nods his head.) God, she's gone through a lot. If you only knew. (Mr. Rafferty begins to sob.) I don't know how she does it. (Clinician hands Mr. Rafferty a tissue.)
- Clinician:** I've got a feeling you're one of the reasons she does okay. You look like you really love her. (Patient nods.) Mr. Rafferty, if you can, tell me what happened after you took the pills. **(Behavioral Incident)**
- Patient:** I didn't want to bother Jennifer; Lord knows she has enough trouble sleeping, but I knew I was in real trouble. I felt foolish, but scared at

what I did, so I called my best friend. He lives next door. Ken came right over.

- Clinician:** What did he say? **(Behavioral Incident)**
- Patient:** He told me I needed to go to the hospital.
- Clinician:** What did you think? **(Behavioral Incident)**
- Patient:** I didn't want to go. But I felt so damn beaten, I just did what he said.
- Clinician:** How do you feel now about having stopped yourself?
- Patient:** Good, I guess.
- Clinician:** You guess?
- Patient:** Yeah. I just don't know how we're going to get through all this (pause). I guess we just have to.
- Clinician:** Have you been feeling hopeless? **(Behavioral Incident)**
- Patient:** Off and on. I feel better today. Sometimes, I think it's not so much hopeless as helpless. There's nothing I can do to stop this. And now everyone's telling me she needs more care.
- Clinician:** When you say you've felt hopeless off and on, I'm wondering what other kinds of thoughts about killing yourself you may have had, say, over the past couple of months? **(Gentle Assumption)** (Note that the clinician has smoothly entered the next region of the CASE Approach, Recent Events.)
- Patient:** Not much really. I don't think I'd ever really kill myself. It's just not the right thing to do.

So far the clinician has done a good job of exploring the area of the Presenting Event, which in this case included a small overdose, always attending to the engagement process, while consciously sticking to the task of creating a step-by-step "verbal videotape." Important information has been shared.

The situational stress that Mr. Rafferty is experiencing is certainly daunting. It is not going to get better, and periods of hopelessness of a much deeper nature may certainly arise. There is certainly a sense of demoralization, understandably so, echoed in Mr. Rafferty's halfhearted relief at having stopped short of actually killing himself. On the positive side, through the skillful use of Behavioral Incidents, the clinician has a good sense of the events of the evening. There appears to have been little immediate premeditation, and the attempt was certainly a small one. It is also promising that Mr. Rafferty sought help quickly. (He was also very cooperative in the emergency room and appeared quite remorseful that he had tried to kill himself.) In addition, he is also indicating that he no longer views suicide as a good option. (Witness his comment, with a sincere tone of voice, "I know suicide is not the answer.")

In a general sense, Mr. Rafferty also seems to convey a sense of being fairly uncomfortable with suicidal ideation. It would certainly be easy for any clinician, especially a

busy one, to assume that there has been little previous contemplation of suicide. Such premature assumptions can be dangerous.

In this regard, it is easy to be lulled into a relatively cursory examination of the period of time 2 months before the presentation, especially if the patient appears to have the current suicidal ideation under control, as with Mr. Rafferty. But limited explorations of this critical 2-month time frame are, in my opinion, one of the major reasons that clinicians leave an initial interview with a faulty understanding of the seriousness of a patient's risk for suicide.

Many times patients will erect a facade for the mental health professional or the primary care physician while describing the suicide event that led them to seek help. This barrier may sometimes arise out of a sense of embarrassment or perhaps because the patient is genuinely feeling a little better since sharing his or her pain at the time of presentation. Such a reassuring interplay can lull the clinician into a false sense of security. Suicide usually requires considerable forethought and internal debate arising from many days of intense pain. The degree to which this pain has taken the patient to the edge of suicide in the recent past may serve as one of the best indicators of whether the patient will cross that line in the near future.

**Step 2: Exploration of Recent Suicidal Events**

In this region, the clinician will elicit the types of suicidal thoughts and actions the patient has had during the previous 6 to 8 weeks, hoping to gain insights into the degree of the patient's suicidal planning and intent. The more concrete and thorough the planning and the more frequent and intense the ideation, the more concerned the clinician should be about acute suicide risk. This area also provides wonderful insight into the patient's weighing of the pros and cons of suicide, including the patient's thoughts of what death will bring, all of which can provide insight into the patient's immediate dangerousness.

Vague forays, such as "How much have you been thinking about suicide?" and "Have you thought about any other ways?" if left alone, are invitations for miscommunication and underreporting of suicidal ideation. With the CASE Approach, this area is explored by determining exactly what types of plans for suicide the patient has had and how far the patient acted on them. Such concrete behavioral information can provide a more valid measure of lethality than clinical conjecture. This process unfolds best by determining (1) which specific plans have been contemplated, (2) how far the patient took actions on these plans, and (3) how much of the patient's time is spent on these plans and accompanying ruminations about suicide.

The amount of this data is formidable in scope, although obviously of critical value. The goal for the front-line clinician is to gather the most valid and comprehensive data to allow the most educated guess—for it is always a guess—about the patient's lethality potential. But

**Figure 2. Exploration of Recent Suicidal Ideation**

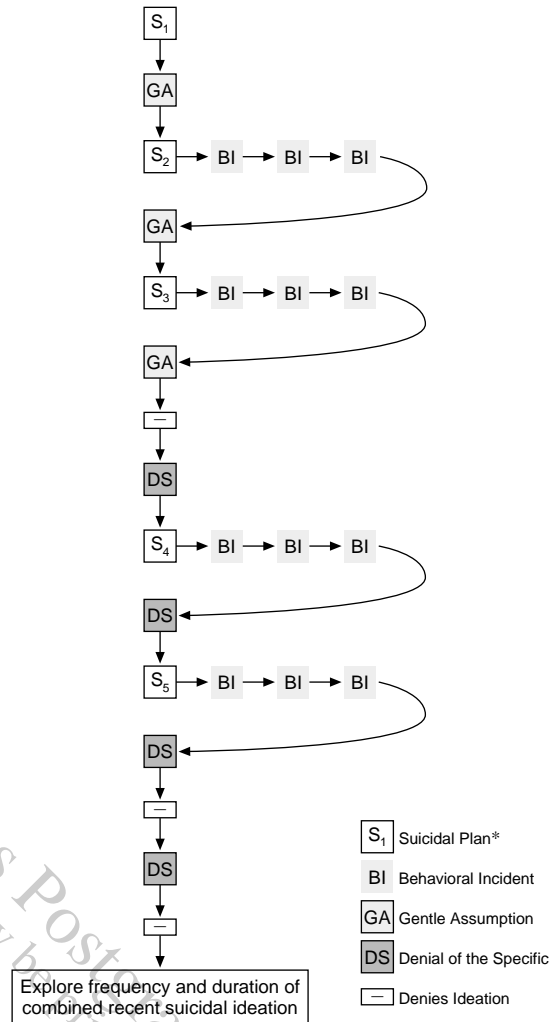

\*Each different subscript indicates new suicide ideation.

the interviewer wants to guess based on the best information regarding the patient's state of mind. Fortunately, as in the Presenting Event, the tools necessary to do the task engagingly and quickly already exist. This time, the technique of the Behavioral Incident will be coupled with the two other validity techniques described earlier, Gentle Assumption and Denial of the Specific.

This paper describes two different strategies for exploring the area of Recent Suicidal Events, but the reader should feel free to design new approaches as needed. No "cookbook" approach is correct, but these principles can make the exploration of recent ideation and actions surprisingly easy and natural.

The first approach is straightforward (Figure 2). After the clinician has completed the region of the Presenting Event, Gentle Assumption is used to reveal the next method of suicide considered by the patient, perhaps a gun. The clinician then uses a series of Behavioral Inci-

dents to establish how far the patient acted on this method. If the patient responds affirmatively to each question, the series may look something like this: “Do you have a gun in the house?” “Have you ever gotten the gun out with the intention of thinking about using it to kill yourself?” “Have you ever loaded the gun?” “Have you put the gun up to your body or head?” “How long did you hold the gun there?” “Did you take the safety off?” “What stopped you from pulling the trigger?”

Once the clinician knows how close the patient came to completing suicide with this method, the clinician once again uses Gentle Assumption to establish a third method. This method is then explored, using Behavioral Incidents in exactly the same manner as before. Gentle Assumptions are then used with follow-up Behavioral Incidents until the patient denies other methods.

Once the use of a Gentle Assumption yields a blanket denial, the clinician uses Denials of the Specific repeatedly. This technique can be surprisingly effective at uncovering previously denied sensitive material. The interviewer doesn't use an exhaustive series of Denials of the Specific but simply asks about any methods common to the patient's culture that have not been discussed yet. For example, if the patient has talked about overdosing, guns, and driving a car off the road, the clinician may employ the following short list of Denials of the Specific: “Have you thought about cutting or stabbing yourself?” “Have you thought about hanging yourself?” “Have you thought about jumping off a bridge or other high place?” “Have you thought about inhaling carbon monoxide?” Such questions often uncover more ideation and, in a few instances, recent attempts that were denied earlier are uncovered. As before, if a new method is uncovered, the clinician uses a series of Behavioral Incidents to find out how far the patient took action.

After completing these explorations, the clinician then focuses on the frequency, duration, and intensity of the suicidal ideation with a question such as: “Over the past 6 to 8 weeks, roughly how much time daily have you devoted to thinking about killing yourself?”

This approach is logical and simple to remember. It also flows imperceptibly for the patient, frequently increasing engagement as the patient is pleasantly surprised at how easy it is to talk to the clinician about material that had frequently been a shameful topic for the patient. The clinician will use this approach to shed new light on Mr. Rafferty's suicide potential:

**Clinician:** When you say you've felt hopeless off and on, I'm wondering what other kinds of thoughts about killing yourself you may have had, say, over the past several months.  
(Gentle Assumption)

**Patient:** Not much really. I don't think I'd ever really kill myself.

**Clinician:** Well, what other ways have even crossed your mind? (Gentle Assumption)

**Patient:** (Mr. Rafferty reflects for a moment, looking away.) I thought of hanging myself. I knew a neighbor who did that once, but I dropped that idea real fast. I'd never do that.

**Clinician:** Why not?

**Patient:** Too unpleasant. Too much pain. I've never even really understood how people get it to work.

**Clinician:** Did you get a rope out or anything else, thinking about hanging yourself? (Behavioral Incident)

**Patient:** No. It's just not the way I'd ever try it.

**Clinician:** What other ways have crossed your mind? (Gentle Assumption)

**Patient:** Nothing really. I'd never shoot myself or do anything violent like that. It's really a stupid thing to do.

**Clinician:** You say that with real certainty. Had you had some thoughts about shooting yourself? (Behavioral Incident)

**Patient:** Sort of. But believe me, I wouldn't do it.

**Clinician:** Do you have a gun at home? (Behavioral Incident)

**Patient:** Did. I'm a hunter.

**Clinician:** Did?

**Patient:** Yeah. I got them out of the house.

**Clinician:** Why was that?

**Patient:** (Looks a bit sheepish.) Well, I was sort of afraid I might hurt myself with them.

**Clinician:** Had you ever picked up one of your guns with the thought of killing yourself? (Behavioral Incident)

**Patient:** Not one of the hunting rifles. But about a month ago I got out a pistol I kept in my night stand in case of burglars.

**Clinician:** Did you get the gun out specifically with thoughts of shooting yourself? (Behavioral Incident)

**Patient:** Yes. Yes I did. I was really depressed then. Much worse than now. That time, and it's the only time I remember, I'd really been thinking about killing myself.

**Clinician:** Did you load the gun? (Behavioral Incident)

**Patient:** I not only loaded it. I put the barrel in my mouth.

**Clinician:** Wow. Close.

**Patient:** I guess.

**Clinician:** What happened next? (Behavioral Incident)

**Patient:** I would put it up and then take it down for a while. Sort of trying to get up my courage. But I was scared. It's so final. And then I began to think about Jennifer finding me. I wouldn't want her to find me like that. That's



really unfair. That would be a horrible thing. And then I thought about what it would mean to her. I mean, if she really does have to go into that nursing home, she'll really need me. I'm her only real support. We don't have any kids. (Eyes well up with tears.) I can't do that to her. That would be a cowardly thing to do. She's an amazing person. Despite everything she's gone through, she still seems to get something out of life. In fact, she told me the other day that she still loves life, that every day is a gift from God. She's just amazing. I'd have to be there for her.

**Clinician:** Did those thoughts actually go through your mind that night? (**Behavioral Incident**)

**Patient:** Oh yeah. I told myself, "This is really stupid." And that's when I put the gun down for good. I decided right then and there that I would never kill myself. That's why I told you I was really puzzled by my taking those pills last night. I really thought I'd never get that close again.

**Clinician:** Did you get all the guns out of the house? (**Behavioral Incident**)

**Patient:** Absolutely. I gave them all to Ken. (Smiles.) I think it scared the shit out of him. He begged me to go see somebody then for help, but I wouldn't do it. I didn't tell him about putting the gun in my mouth or anything like that. I just told him I thought it was a good idea for me to get rid of the guns. You should have seen his eyes (pause). He really is a good friend. I didn't mean to scare him (pause). You know, I actually felt better for a while too. I really did. I wasn't kidding him. But it caught up to me again this past week.

**Clinician:** Mr. Rafferty, what other ways have you thought about killing yourself? (**Gentle Assumption**)

**Patient:** None. That's enough, isn't it? (Smiles again.)

**Clinician:** (Chuckles a bit.) Yeah. I'd say so. What about cutting yourself or stabbing yourself? (**Denial of the Specific**)

**Patient:** Never even gave it a thought.

**Clinician:** Carbon monoxide poisoning? (**Denial of the Specific**)

**Patient:** Nope. Don't have a garage.

**Clinician:** How about driving your car off the road? (**Denial of the Specific**)

**Patient:** That one I thought about.

**Clinician:** Did you ever get into your car with the intention of doing that? (**Behavioral Incident**)

**Patient:** No. It was just a quick thought, sometimes when I'm driving, but it goes away quick.

**Clinician:** How about drowning or jumping off a building? (**Denial of the Specific**)

**Patient:** No way. Really, the only way I ever gave it much thought was the gun, because I had so many of them around. But like I said, that would be a betrayal of Jennifer. That's a coward's way out. And I'm not going to do it. That's why I'm here today. You know, I spent my life telling kids on my football team to never give up. Didn't matter if we were last in the conference or conference champs. We never gave up. I'm not going to now.

**Clinician:** That's good to hear, Mr. Rafferty. It's obvious to me that you really do have some real inner strength. I hope you realize that. (Mr. Rafferty nods.) And it looks like you have a very powerful reason to live, helping your wife. (Mr. Rafferty nods agreement.) I was wondering, over the past 2 months, how much time have you been spending thinking about various ways of killing yourself, just so I make sure I have a clear idea of this? (**Behavioral Incident**)

**Patient:** That's hard to say.

**Clinician:** Couple of hours a day, 4, 6 hours, most of the day? (**Behavioral Incident**)

**Patient:** Like I said, it really varies. Back with the gun, I'd been thinking about it a lot, like all day long for several days. But since then not much. I just sort of cracked last night. But I hadn't been thinking about it much.

**Clinician:** How about in the past? Have you ever actually tried to kill yourself? (Movement into the area of Past Suicide Events.)

This interview has proceeded well, and much information has come to light. Some promising signs emerge here. Mr. Rafferty is clearly denying current intent in a believable way. Without any prompting from an outside source, he also quickly removed all the guns from his house, showing a real instinct for self-protection. He seems to have a strong superego, which helps him to avoid suicide. His framework for meaning, centered around his wife, sounds powerful and genuine.

Mr. Rafferty's affect has also improved as the suicide assessment has progressed. There is some genuine humor near the end, and he is building a bond with the interviewer. This second consecutive positive contact with a mental health professional could motivate him to investigate aggressive outpatient care such as the crisis group.

The clinician has also deftly uncovered a background of suicidal ideation, with some significant actions toward suicide, that might easily have been missed with other approaches. Mr. Rafferty's suicide risk is to be taken quite seriously. The clinician has gained a much more accurate sense of the severity of Mr. Rafferty's moments of despondency, as evidenced by the incident with the gun. The

risk is emphasized by the seriousness of the method contemplated, the extent of action taken, and the premeditation involved over the course of days. Coupled with the somewhat curious impulsiveness of the previous night, this new material, gained from a careful exploration of the previous 2 months, sheds new light on his possible risk.

For instance, if Mr. Rafferty were to demonstrate any “gaminess” about his safety in the rest of the interview (although this does not appear likely; he truly sounds motivated for care) or to refuse further follow-up, the clinician now has enough background information to recommend hospitalization, even commitment if necessary. Note that the careful and persistent use of Gentle Assumptions and Behavioral Incidents has led to some very strong evidence for an involuntary commitment, if needed. A judge is much more likely to be impressed with a gun in the mouth than with a relatively small overdose.

The excerpt also highlights one of the complicating factors for primary care clinicians, who are operating under extreme time constraints. If the above interview were occurring after a primary care physician had astutely perceived a patient’s depression during a routine visit, perhaps for back pain in Mr. Rafferty’s case, it would be extremely easy to have ended the suicide assessment after the exploration of the *presenting* suicidal ideation. By that time the physician would have determined that a prompt referral to a mental health colleague was in order. The triage decision would already have been made. Since earlier questions would have revealed the presence of depression, and since Mr. Rafferty appeared to be in good control of current suicidal ideation, the clinician would have been tempted at this point to raise the issue of antidepressant use and then discuss referral to the mental health colleague.

But without having explored the previous 2 months, the physician would have known nothing about Mr. Rafferty’s guns or the severity of his depression only a month ago. Many patients in primary care do not want to see a psychiatrist or a therapist. And although they may be well-known to the physician and appear motivated while talking about their presenting depressive symptoms and suicidal ideation, the patient may change quickly when the actual referral is made and respond, “I’d really prefer that you just start the antidepressant; let’s see how that goes first.”

If the primary care clinician had uncovered the information from the previous 2 months, this option would clearly not have appeared to be a good one. Mr. Rafferty is not a good candidate for monthly monitoring. His suicidal ideation and impulsivity require weekly suicide assessment and support. But if the clinician had lacked the information elicited by exploring the last 2 months carefully, the correct triage decision would have been more elusive.

Not having explored the previous 2 months, thus not being privy to the gun incident, our theoretical primary care physician is faced with a dilemma now. Technically, there are grounds for commitment (the overdose) to use as

leverage to push the patient toward follow-up, but without the gun information, they are weak. Moreover, the depth of the suicide potential might not even have appeared serious to the physician without the information about the gun, which would only be available if the clinician had done a careful exploration of the past 2 months of ideation. If the physician now asks to hear more about any other suicidal ideation, the patient may fall silent, well aware that sharing the gun information is tantamount to voluntary hospitalization or commitment. Validity and engagement can plummet once the patient senses that a control battle is brewing.

An even more likely scenario would involve a patient who accepted the referral but had some misgivings that became rationalizations as the week progressed: “I don’t really need to see a therapist. I’m just gonna stick with these pills. I really don’t want to share all this stuff again. I’m okay. I feel a little better. Dr. Jenkins will help me.” The patient subsequently fails to appear at the mental health clinic, and the therapist forgets to alert the referring physician of the breakdown in follow-up. Later in the month Mr. Rafferty misses his next primary care appointment because of a legitimate conflict involving a sudden need to help his wife at home. Now a patient who had a gun to his mouth only a month ago, a fact no one knows, is without any sound follow-up. If the depression suddenly worsens and the hopelessness settles in again, a phenomenon toward which Mr. Rafferty has already shown a propensity (another fact no one knows), Mr. Rafferty may become one of the 50% of patients who complete suicide after having seen a primary care physician recently.

The CASE Approach provides a time-efficient and reliable answer for the busy primary care physician. It reminds the primary care physician that the suicide assessment is not complete after the exploration of presenting suicidal ideation, even though it might already be quite apparent at this point that a mental health professional referral is indicated. The area of recent ideation must also be explored before any referral options are mentioned. No matter how obvious it is that a referral to a mental health professional is indicated, the suicide assessment is not complete until the primary care physician has searched for the best grounds for commitment to invoke as leverage to ensure follow-up, if necessary, in a patient who refuses referral (less common) or in a patient who does not show up for the referral (more common).

The sample dialogue above also demonstrates a beneficial result of using Behavioral Incidents to uncover the extent of action taken toward self-harm. Patients describing their actions often spontaneously discuss their arguments for and against killing themselves. These arguments often provide important clues to their vulnerability to suicide. For instance, in the above excerpt, while explaining why he stopped himself from using the gun, Mr. Rafferty raised both the issue of the need to care for his wife and his con-

Figure 3. Alternative Exploration of Recent Suicidal Ideation

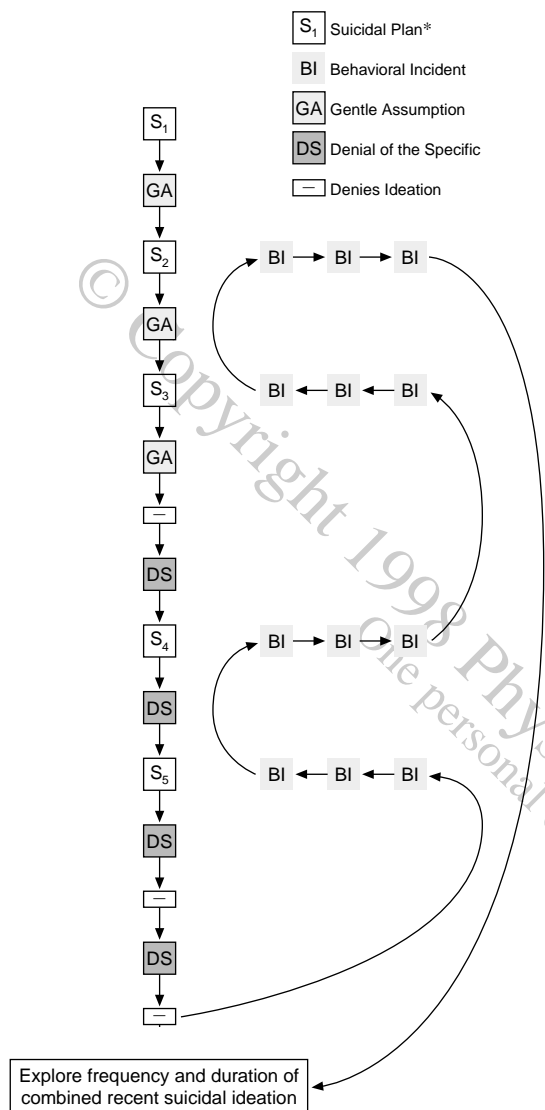

\*Each different subscript indicates new suicide ideation.

viction that, from his framework of meaning, it was not appropriate to give up. Both of these beliefs represent important deterrents from his perspective. In fact, the genuineness and power of these constraints provide some of the most convincing arguments that Mr. Rafferty can be handled safely as an outpatient with close follow-up.

There are other ways to approach the task of exploring the region of Recent Events. In another popular method (Figure 3), the clinician first generates the entire list of suicide methods contemplated by the patient and then explores each one in detail.

In this approach, after the clinician has explored the presenting method, Gentle Assumption is used to find out the second method, if indeed one has been considered. In the first approach, the clinician would have next used Behavioral Incidents to delineate the extent of action taken

with this new method. In this alternative approach, however, the clinician uses another Gentle Assumption, for example, "What other ways have you thought of killing yourself?" as soon as the second method is discovered. This use of Gentle Assumptions is continued until the patient provides no other methods, at which point the clinician uses Denial of the Specific repeatedly until the list is complete.

At this juncture the clinician then returns to each suicide method in turn, using a series of Behavioral Incidents to find out how far the patient has gone in taking actions toward self-harm. For instance the clinician might say, utilizing an internally referred opening, "Earlier you mentioned that you had thought of shooting yourself. Is there a gun in the house or one available to you?" A series of clarifying Behavioral Incidents concerning the actions taken with the gun would follow. Having determined the patient's extent of action with this second suicide method, the interviewer would use the same approach with method number three, repeating this course until all methods had been discussed.

Just as with the first strategy, after all methods are explored with Behavioral Incidents, the clinician checks on the frequency, duration and intensity of the recent ideation with a question, such as "Looking at all these methods combined, over the past 6 to 8 weeks, how much of any given day are you spending on thoughts of suicide?"

Both strategies are easy to remember. In the first, as each method is uncovered, the clinician uses Behavioral Incidents to follow the extent of action taken. In the second, a list of all the methods is uncovered before any of them is explored in detail with Behavioral Incidents. The reader can try both strategies or develop entirely new ones. There is no correct strategy. But the art is consciously to employ a specific interview strategy, a strategy with which the clinician can become familiar and that can be reliably employed rather than relying solely on intuition or habit.

After the clinician is finished exploring recent ideation, there is still more investigative work to be done, for a history of serious suicide attempts in the past could change the triage decision.

### Step 3: Exploration of Past Suicidal Events

Clinicians sometimes, during the initial interview, spend too much time on this area. Patients with extensive histories of suicidal attempts and gestures, as seen with some people suffering from a borderline personality disorder, may have lengthy past histories of suicidal material. One could spend an hour just reviewing this material; it would be an hour poorly spent.

Under the time constraints of busy practices and managed care, initial assessments by mental health professionals usually must be completed in an hour. Primary care clinicians, even more harried by time constraints, usually have about one-half hour to complete an initial history and

physical examination, with only about 7 to 15 minutes for a routine office visit. Time is at a premium. What past suicidal history is important to gather? One can argue that only the information that could potentially change one's decision about the safety of the patient is essential. Thus, the following questions require investigation:

1. What is the most serious past suicide attempt? (Is the current ideation focused on the same method? "Practice" can be deadly in this arena. Does the patient view the current stressors and options in the same light as during the most dangerous past attempt?)
2. What is the approximate number of past gestures and attempts? (Large numbers here can alert the clinician to issues of manipulation, making one less concerned, or may alert the clinician that the patient has truly exhausted all hope, making one more concerned. In either case, it is important to know.)
3. When was the most recent attempt?

The above questions will secure the information that could alter the clinician's triage decision about safety. For instance, if one were to discover that Mr. Rafferty had actually taken a very serious overdose, requiring a stay in an intensive care unit, about a year ago, this information would make one considerably more concerned about his current safety. In Mr. Rafferty's case, if the clinician uncovered such unexpected material, it would be quite alarming given that Mr. Rafferty had not mentioned it earlier and had, indeed, been implying that suicide was quite foreign to him. In a similar vein, if Mr. Rafferty admitted to a string of attempts or gestures in the past, one would have to question the reliability of his current assurances of safety.

Let us return to our excerpt at a point where the clinician is beginning to explore Past Events with Mr. Rafferty:

**Clinician:** How about in the past? Have you ever actually tried to kill yourself, even when you were a child or a teenager? (**Behavioral Incident**)

**Patient:** Not really.

**Clinician:** How about even vague thoughts? (**Behavioral Incident**)

**Patient:** I had a spot in my sophomore year in college, where it crossed my mind.

**Clinician:** Oh. Tell me about that. (**Behavioral Incident**)

**Patient:** It was really nothing. I had failed an advanced algebra course. I was really worried about what my father would say. I always got pretty good grades. I remember thinking, "Man, I had better kill myself." But I dropped the idea quick.

**Clinician:** How were you thinking of killing yourself? (**Behavioral Incident**)

**Patient:** Oh my gosh, no way came to mind. I mean I

barely gave it a second thought.

**Clinician:** What other ways have you ever thought about, if any, Mr. Rafferty? (**Gentle Assumption**)

**Patient:** That's it. I've never ever thought about it before. I mean, in college that was just a split-second kind of thing. I mean, I never gave it any serious consideration (pause). You know, like everybody else in this world, I've had a lot of tough times in my life, lost my only child to leukemia, divorced once, death of my brother, but I've never had thoughts of killing myself until recently. It just never crossed my mind. In fact if I heard that someone had killed themselves, I would always wonder why one would ever do that. I just couldn't see it (pause). I guess I see it a little differently now.

This part of the interview is finished quickly, revealing little troubling information. The clinician followed up at one point with "How about any vague thoughts or feelings?" wisely investigating Mr. Rafferty's response, "Not really." The only ideation uncovered proved to be of little consequence, merely the panicked first thought of a college student anticipating a bad phone call home. Otherwise, Mr. Rafferty's history is consistent with his earlier claim that suicidal thinking was not a part of his past.

Having finished an exploration of Past Events, the clinician will now turn to the single most important time frame, the present.

#### **Step 4: Exploration of Immediate Events**

This area focuses on the question, "What is this patient's current suicidal intent?" The clinician explores any suicidal ideation that the patient may be experiencing during the interview itself. The interviewer also inquires whether the patient anticipates thoughts of suicide after he or she leaves the office or emergency room. The content of this area is easily remembered as devoted to the time frames Now/Next.

It cannot be emphasized enough that continuing concerns about the safety of the patient or the validity of the patient's self-report require contacting corroborative sources. In the case of Mr. Rafferty, if the crisis worker had not already contacted his best friend and his wife, then both of them would be important contacts for the clinician currently evaluating Mr. Rafferty. (The crisis worker had met with both support members the night before, finding them very concerned and responsible.) It is important to evaluate existing support structures and, if need be, design specific interventions and plans for their use.

In this region of the CASE Approach, the task of developing crisis plans is frequently facilitated by asking questions, such as "What would you do later tonight or tomorrow if you began to have suicidal thoughts again?" From the patient's answer, one often surmises how serious the

patient is about ensuring his or her own safety and provides a chance to brainstorm and complete plans for just such an occurrence.

Obviously, one also asks the patient whether he or she is feeling suicidal at present with questions, such as "Right now, are you having any thoughts about wanting to kill yourself?"

Such questioning leads the clinician to safety contracting. Remember that safety contracting is no guarantee of safety whatsoever. A patient of mine once took an overdose 2 hours after completing a safety contract in my office.

Can a safety contract act as a *relative* deterrent? We have no conclusive proof. It is probably safe to assume that safety contracts sometimes can function as deterrents. The more powerful the bond with the clinician and the more concrete the contract (e.g., written as opposed to oral), probably the more powerful the deterrent. It is hard to kill oneself. Anything that makes it even harder may function as a deterrent. A sense of commitment and trust with a long-standing therapist can make the patient hesitant to break his or her word. The deterrent power of a safety contract made with a first-time patient is probably markedly less.

Additionally, documenting a safety contract in the initial assessment provides some mild forensic support in a lawsuit by demonstrating that one asked about safety in some detail, making it harder to prove negligence on the clinician's part. This protection is probably enhanced by carefully wording the record of the use of the contract, using behavioral observations that could be of value in defending why the clinician felt the safety contract was a good one. For instance, "The patient was able to make a sound safety contract with me, showing good eye contact, a genuine affect, and a natural and unhesitant tone of voice."

If one is meeting the patient for the first time, for instance in an emergency room, is a safety contract an effective deterrent? This tactic is probably much less effective than in the context of a well-established psychotherapeutic relationship. Still, if the patient has bonded quickly, as Mr. Rafferty did with the crisis worker, Mary, or as he is apparently doing with the current clinician, a safety contract may have a mild deterrent effect.

But deterrence is not the main reason to use a safety contract. The process of contracting for safety is an exquisitely sensitive assessment tool. At the time of presenting the safety contract, the interviewer should search the patient's face, body, and tone of voice for any signs of deceit or ambivalence. Here is the proverbial moment of truth. This juncture of the interview is, potentially, the most powerful indicator of the patient's true suicidal intent.

Using the safety contract as an assessment tool, the clinician may completely change his or her mind about releasing a patient based on hesitancy to contract, avoidance of eye contact, or other signs of deceit or ambivalence. The interviewer who notices such nonverbal clues of ambivalence can simply ask, "It looks as though this contract is

hard for you to agree to. What's going on in your mind?" The answer can be benign or alarming.

There are certain people for whom it is sometimes best to avoid the whole issue of safety contracting. Some patients with borderline or passive-aggressive characteristics may become embroiled in manipulation around safety contracting issues, tossing out lines, frequently around 2:00 a.m. in a teeming emergency room, such as "I don't know what to tell you. I guess I'm safe, but on the other hand, I can't make any guarantees. Do you know anybody who can?" Whether or not to use safety contracting with people suffering from severe character disorders is often best addressed by talking directly with the patient's ongoing treatment team or therapist.

A final note on this region: It is important to explore the patient's current level of hopelessness and to assess whether the patient is making productive plans for the future or is amenable to brainstorming concrete plans for dealing with current problems and stresses. It is important to see if the patient is interested in follow-up mental health care.

This issue can play a pivotal role in primary care suicide assessment, as mentioned earlier. Any hesitancy by the patient at this point of the interview may warn an astute primary care physician that the patient's follow-up must be changed from a week hence to later the same day, with a mental health professional such as a crisis clinician. The more familiar the primary care physician becomes with using the process of safety contracting as an assessment tool of the patient's ability to make it safely to his or her appointment with a mental health professional, the more skilled the physician becomes at intuitively spotting patients who are having second thoughts about suicide. On the other hand, in my opinion, the primary care physician should leave the use of long-term safety contracting to mental health professionals.

Let us look at an exploration of this last region of the CASE Approach with Mr. Rafferty:

**Patient:** . . .but I've never had thoughts of killing myself until recently. It just never crossed my mind. In fact, if I heard someone had killed themselves, I would always wonder why one would ever do that. I just couldn't see it (pause). I guess I see it a little differently now.

**Clinician:** What about right now, Mr. Rafferty? What kinds of thoughts, if any, are you having about killing yourself? (**Gentle Assumption**)

**Patient:** None. Last night, when I stopped, I really knew that this was not for me. But the other thing is that, after Mary met with my wife and myself last night, and we talked about how I was feeling, I really realize that she needs me even more. She was really shocked at how depressed I've been. I guess I put on a good front. But it was plain to me that there was

help for me, too. It was good to get all of this out in the open.

**Clinician:** Sounds like it was really valuable for you last night. By the way, Mary said your wife was a delight. (Mr. Rafferty smiles.) I'll be wanting to talk to her as well, if that's okay with you.

**Patient:** Absolutely. I think you should.

**Clinician:** Of course your wife's medical situation has not changed since last night, and I know you were feeling hopeless about it last night. Are you feeling hopeless now?

**Patient:** (Mr. Rafferty sighs.) Well, not hopeless. It's bad, and we're heading for tough times. But I guess, if we face those times together, that it will all be worth it in the end. I don't think there is anything else one can do. You just trust in yourselves and God. I guess that's all you can do.

**Clinician:** That sounds like a good plan. Hopefully we can help too. By the way, if you ever feel the need to talk, 24-hours a day, you can reach our crisis line.

**Patient:** I know that now. But I'm not going to kill myself.

**Clinician:** Mr. Rafferty, can you promise me that you would call our crisis team at any time of the day or night if you start to get suicidal thoughts again and that you won't act on those thoughts?

**Patient:** I sure can.

**Clinician:** Can you shake on that?

**Patient:** (Mr. Rafferty smiles.) Sure can. (They shake hands.)

**Clinician:** That's great. By the way, had Mary talked much about our Crisis Group?

**Patient:** Just a little. But it sounded like it might help a lot.

**Clinician:** I'm going to want to explain all about it, as well as some other options we have for helping, later in the interview. First, I'd like to hear just a little more about your sister, because I think you mentioned earlier that she had a depressed spell. Is that right?

**Patient:** Oh yeah. She has had several pretty bad depressions.

**Clinician:** Do you know if she has been helped by any medications? (The clinician has smoothly moved on to the Family History. The suicide assessment is complete.)

Earlier in the interview, the clinician had identified all important statistical risk factors that were weighed in the decision-making equation, as the CASE strategy helped to cull more and more pertinent data about suicidal ideation itself. Mr. Rafferty, as it turns out, drinks very little alco-

hol, has never used street drugs, and is in good health himself. There was no psychotic process. In addition to his best friend and his wife, Mr. Rafferty had a good set of supportive friends.

From the data gathered from the rest of the interview, it was apparent that Mr. Rafferty had been a high-functioning individual who had apparently developed a fairly severe major depression. Note also his spontaneous relief at being given a chance to share with his wife what had been happening to him recently, including his suicidal ideation. His relief seemed genuine, and this new opportunity for communication with his wife bodes well for his safety in the future.

The skillful elicitation of the patient's suicidal ideation and behaviors, using the CASE Approach, allowed the clinician to make a decision on acute suicide potential with the most reliable and valid data available. The data helped the clinician to avoid overreacting or underreacting. Mr. Rafferty revealed that he had placed a gun in his mouth while feeling transiently hopeless only because the clinician had carefully explored Recent Events in the 2 preceding months. By uncovering this incident, the clinician was alerted to the seriousness of Mr. Rafferty's potential. Without such knowledge, the clinician could have underreacted by deciding to see Mr. Rafferty relatively infrequently or by failing to realize the importance of creating a sound follow-up plan involving both Mr. Rafferty and his wife.

But the same careful questioning prevented overreaction by uncovering information supporting the idea that Mr. Rafferty was safe to leave and would not require hospitalization. For instance, while describing the gun incident, Mr. Rafferty shared his strong reasons for living, focusing on his need to help his wife and his conviction that one should never quit. Other motivating factors, such as his belief in God, also emerged during the CASE Approach. The CASE Approach helped to uncover a benign past suicidal history as well as a genuine affect while Mr. Rafferty was contracting for safety and discussing follow-up. Coupled with his intention to join the crisis group and the open channels for communication with his wife about safety issues, it was reasonable to treat Mr. Rafferty as an outpatient.

## CONCLUSION

The CASE Approach allows the clinician to enter the patient's world of suicidal preoccupation sensitively and deeply. The information complements a careful review of the risk factors associated with suicide potential. Using both approaches, the clinician can begin to gain a deeper understanding of the potential suicide risk of the patient.

During this assessment process, something else very important has been accomplished, for the interviewer has helped the patient to share painful information that, in many instances, the patient has borne alone for too long. At a dif-

ferent level, perhaps the thoughtfulness and thoroughness of the questioning, as illustrated with the CASE Approach, have conveyed that a fellow human cares. To the patient, such caring may represent the first realization of hope.

Originally developed for use by mental health and substance abuse professionals, the CASE Approach may offer many advantages to primary care physicians as well. Although primary care clinicians are often gifted with an intuitive sense about their patients, the time constraints in primary care settings are daunting, and these time constraints work against the primary care physician's intuitive abilities. More specifically, primary care clinicians (including physicians, nurses, and physician assistants) are frequently working in hectic, fast-paced environments, where one can count on unexpected problems and late hours. Errors are easy to make, and a litigious society adds yet another stressful ramification to such errors. High stress environments, such as typical primary care settings, are exactly the arenas in which clinical intuition fails.

In addition to clinical intuition, the primary care physician may benefit from having a concrete and practical strategy for eliciting suicidal ideation. Such a questioning should be reliable, while avoiding the false positives and red herrings that can be particularly problematic and time-consuming in a primary care setting, where time is at such a premium. In these busy clinics all patients presenting with psychiatric disorders such as depression, panic disorder, posttraumatic stress disorder and substance abuse, in addition to patients suffering from debilitating medical illnesses, must be carefully screened for suicidal potential. The task for the primary care physician is to find a dependable method of conducting such questioning as rapidly as possible while engaging the patient powerfully.

The CASE Approach attempts to fit this need. It is easily learned and easily remembered. When using this strategy routinely, the primary care clinician becomes adept at it, while flexibly altering it to fit the unique needs of the primary care clinical setting. In most primary care suicide assessments, the CASE Approach can be completed within several minutes. As seen with Mr. Rafferty, even more complicated patients rarely require more than 5 to 10 minutes, markedly less time than would be necessary to follow up other potentially life-threatening situations, such as a patient's report of acute chest pain.

The primary care clinician needs a strategy for eliciting suicidal ideation that does far more than suggest whether a referral to a mental health professional is indicated. The strategy must also uncover information that indicates whether the patient is safe to leave the office or must be re-evaluated in the event that the patient balks at the referral or subsequently does not follow through on the referral. In this regard the strategy must uncover information that could lead the primary care clinician to insist on timely assessment by a mental health professional, even commitment if necessary. The CASE Approach provides exactly

this information, as well as information that can help the busy primary care clinician decide how frequently to see the patient and also determine how soon the first appointment with the mental health professional should occur.

The majority of patients treated for depression are now seen within the primary care field. It is no longer appropriate, if it ever was, to view mental health professionals as the only experts in suicide assessment. Primary care clinicians are often the front line for such assessments and must be as expert in their abilities as mental health professionals, who often will never get a chance to evaluate the patient.

In the primary care setting, the implementation and fine tuning of interviewing strategies, such as the CASE Approach, cannot be done by mental health professionals. Such critical ongoing development must be left to primary care clinicians themselves, who are much more aware of the needs of their unique clinical environment, routinely screening for psychiatric disturbances, such as suicidal ideation, in patients presenting only with somatic complaints. On the other hand, specific interviewing methods, such as the validity techniques, and interviewing strategies, such as the CASE Approach, have evolved from the mental health field. In this regard mental health professionals will remain pivotal in the task of training professionals both across disciplines and across clinical settings, always working together with colleagues to ensure the highest possible quality in suicide assessment.

## REFERENCES

1. Roy A. Psychiatric emergencies, suicide. In: Kaplan HI, Sadock BJ, eds. *The Comprehensive Textbook of Psychiatry*, 6th ed. Baltimore, Md: Williams & Wilkins; 1995:1739-1752
2. National Institute of Mental Health: Suicide Fact Sheet (based upon completed suicides in 1993), June 1996 Update
3. Fawcett J, Clark DC, Busch KA. Assessing and treating the patient at risk for suicide. *Psychiatric Annals* 1993;23:244-255
4. Rich CL, Young D, Fowles RC. San Diego suicide study. *Arch Gen Psychiatry* 1986;43:577-582
5. Shea SC, Mezzich JE. Contemporary psychiatric interviewing: new directions for training. *Psychiatry* 1988;51:385-397
6. Shea SC, Mezzich JE, Bohon S, et al. A comprehensive and individualized psychiatric interviewing training program. *Academic Psychiatry* 1989;13:61-72
7. Pascal GR. *The Practical Art of Diagnostic Interviewing*. Homewood, Ill: Dow Jones-Irwin; 1983
8. Pomeroy WB, Flax CC, Wheeler CC. *Taking a Sex History*. New York, NY: The Free Press; 1982
9. Shea SC. *Psychiatric Interviewing: The Art of Understanding*. Philadelphia, Pa: WB Saunders Company; 1988:372
10. Shea SC. *Psychiatric Interviewing: The Art of Understanding*. Philadelphia, Pa: WB Saunders Company; 1988:93-124

## DISCLOSURE OF OFF-LABEL USAGE

The author of this article has determined that, to the best of his clinical estimation, no investigational or off-label information about pharmaceutical agents has been presented that is outside Food and Drug Administration-approved labeling.